

Tate Andale Model KRF Self-Cleaning Strainer

*Where customer needs require custom designs—
The “KRF” is the answer.*

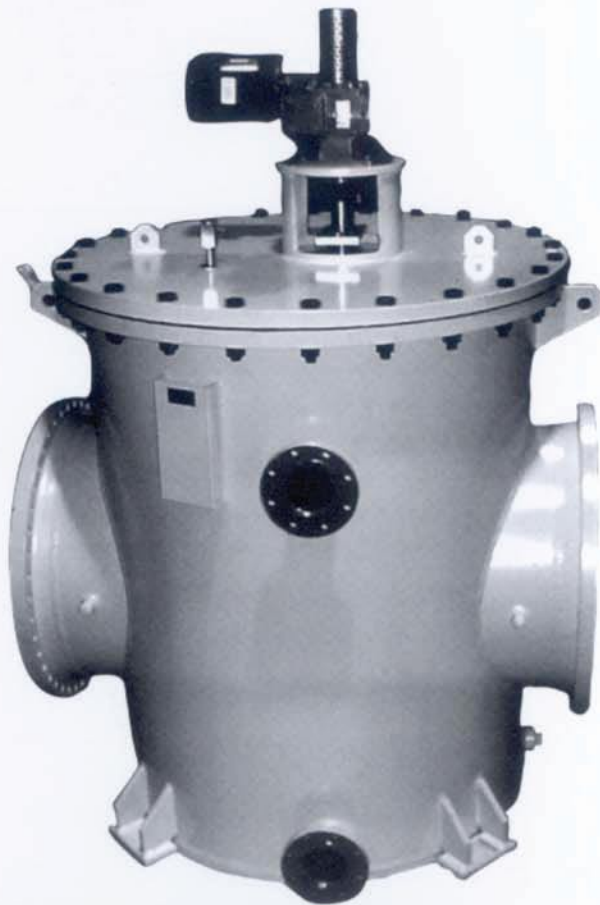

Description

The Model **KRF** is a truly customizable fabricated self-cleaning strainer designed for continuous backflush operation. Featuring a fabricated backwash arm and a single, replaceable element wedgewire basket—both of stainless steel construction—the Model **KRF** is designed to be unattended for extended periods of time. The large amount of open area allows intermittent backflush operation, thereby minimizing both operating costs and backwash effluent. The wedgewire element features a reverse groove design that prevents lodging of debris in the element and creates a vortex during backflush for a more efficient backflush operation. The Model **KRF** can be constructed from a variety of materials—from carbon steel to stainless steel to exotic alloys—or can be coated internally with fusion bonded epoxy finish, allowing it to handle any fluid. For a truly **customizable** strainer that can be designed for any application or budget, not limited by size and pressure, the **KRF** is the finest choice.

Standard Features

- Continuous backflushing
- Carbon steel body with internal fusion bonded epoxy coating
- Replaceable straining element
- Standard C face mounting gear box frame drive motor
- Rotating cleaning arm in contact with 100% of screen element
- Water-lubricated rubber lower bearing
- Replaceable lower bearing (without removing shaft)
- In-line nozzles
- Large blow-down connection

Optional Features

- Automatic intermittent backflushing control to conserve backflushing fluid
- Suction service units available
- Air, electric, or hydraulic operated flushing valves
- Sequential controls for multiple units
- Higher design pressures available

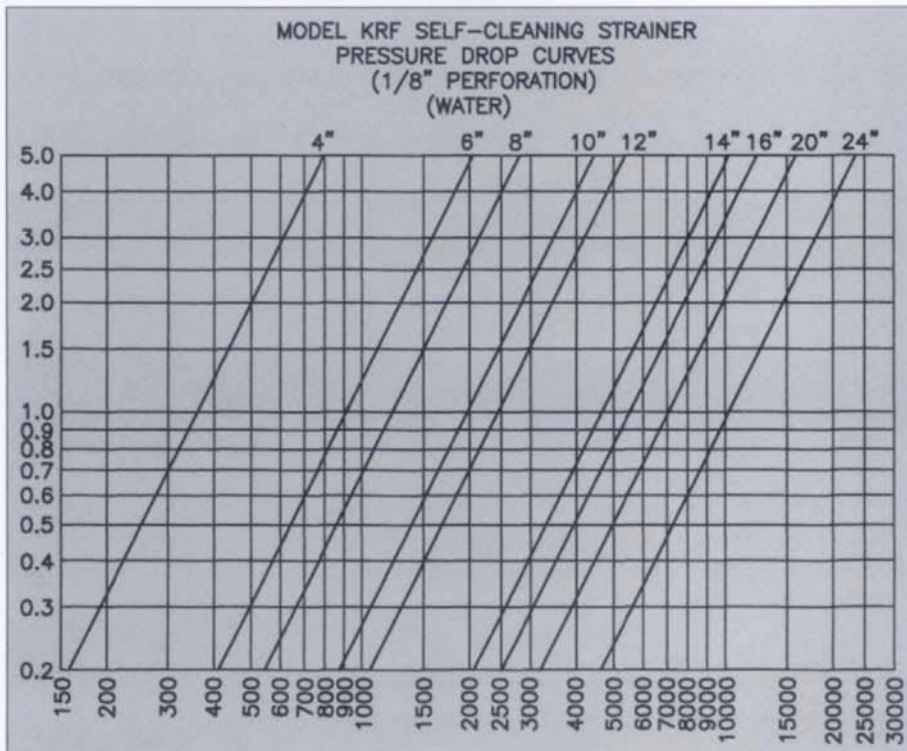

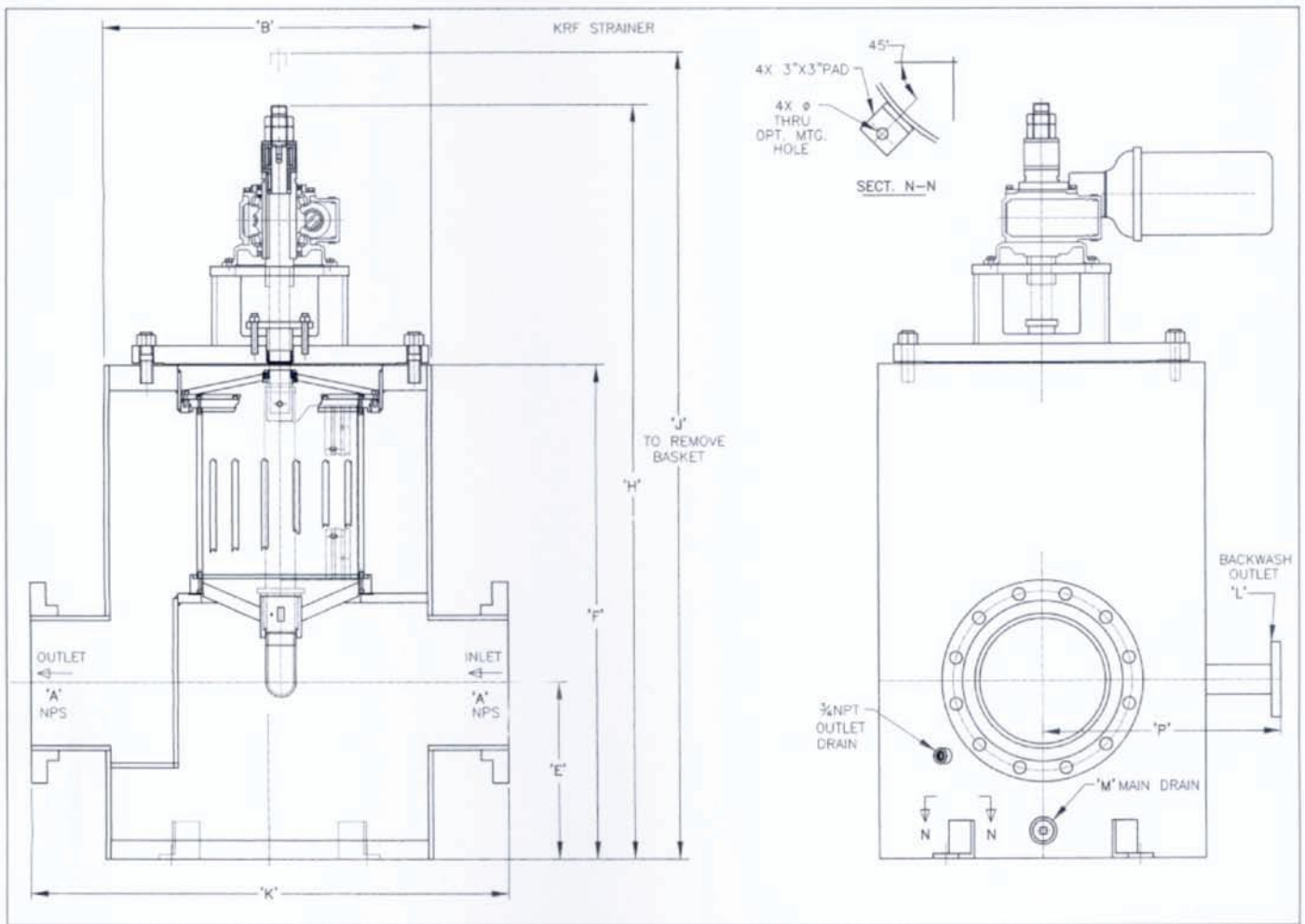

Model KRF Dimensions (Approx.) 150 PSIG

SIZE (Inlet Dia.)	4"	6"	8"	10"	12"	14"	16"	20"	24"
A	4	6	8	10	12	14	16	20	24
B	14	14	14	26	26	32	32	42	46
E	8	8	8	14	14	16	16	18	18½
F	24	24½	28½	39½	47	49	59½	52½	74½
H	42	42½	46½	58½	66½	68½	77	86½	96
J	52	52½	56½	105	119	130	138	149	169
K	26	26	26	38	38	44	44	54	58
L	2	2	2	2	2	3	3	4	4
M	1½	1½	1½	2	2	2	2	3	3
P	13	13	13	19	19	22	22	27	27
MOTOR H.P.	½	½	½	½	½	½	½	½	½
WT. DRY (lbs.)	440	460	500	650	1508	2252	2403	4098	5289
WT. WET (lbs.)	560	590	1350	2015	2345	3546	4007	7050	10,068

Dimensions are for reference only. For installation purposes, request certified drawings. Specs larger than 24" are available upon request.