

Tate Andale Model GS Simplex Strainer



Description

Tate Andale Model GS single-basket strainers are available in cast iron, cast steel and cast stainless steel bodies.

This uniquely designed **Model GS** is available in sizes 2-inch through 8-inch. Threaded units are available in 2-inch to 3-inch sizes. Flanged units are available in 2-inch to 8-inch sizes.

These precision fitted, top-entry basket units feature knob-type, quick opening, positive seating covers that do not require tools to operate. All units have standard O-ring seals. The units are designed for use in system pressures up to 200 W.O.G.

Each unit comes with an industry standard basket that is easy to remove and clean. Units that are 2½ inches and larger are designed with a stainless steel wedgewire basket. Two-inch and smaller units are designed with a stainless steel perforated plate basket.

Model GS strainers are recommended for batch operations where flow may be interrupted to clean the basket. Typical applications include those with small amounts of debris or for start-up or emergency protection.

This compact, trouble-free strainer has been designed to be interchangeable with most standard competitive brands of similar material and size.

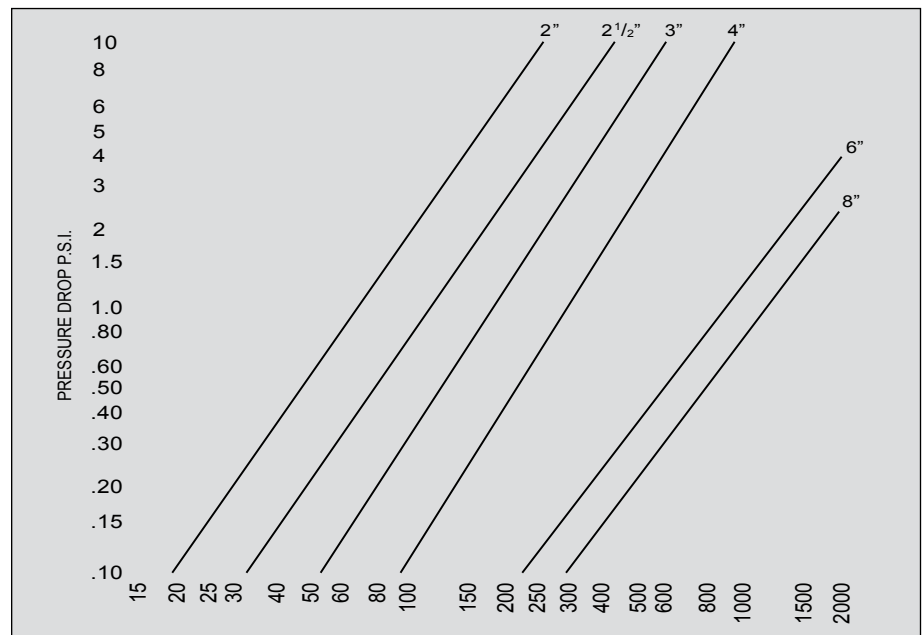
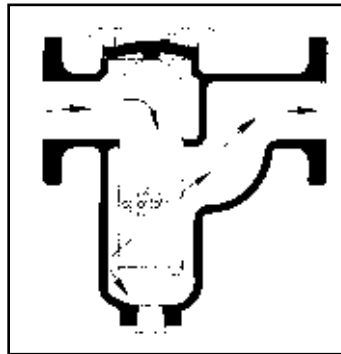

FLOW RATE (WATER) G.P.M.

Tate Andale Model GS Simplex Strainer

Standard Features

- Choice of cast iron, cast steel or cast stainless steel
- Sizes from 2-inch to 8-inch
- All flange connections meet ANSI standards
- Rated to 200 W.O.G.
- High straining ratios
- Knob-type, positive seated cover allows quick access to basket and requires no tools to operate
- Standard O-ring seal
- All designed with a stainless steel basket
- Two-inch and smaller units have a perforated plate basket
- 2½-inch and larger units have a wedgewire basket
- Easy installation and service, no maintenance tools needed
- GS spare parts have been designed to be interchangeable with Guardian Duplex parts
- Most sizes available from stock
- Model is interchangeable with most competitive brands

Optional Features

- Basket available in most perforation or mesh sizes
- Basket available in other materials

Selection Consideration

- The **Model GS** is applicable for batch operations where the pipeline flow can be interrupted for basket cleaning.
- The **Model GS** is the preferred unit for the majority of industrial straining applications requiring standard simplex units.

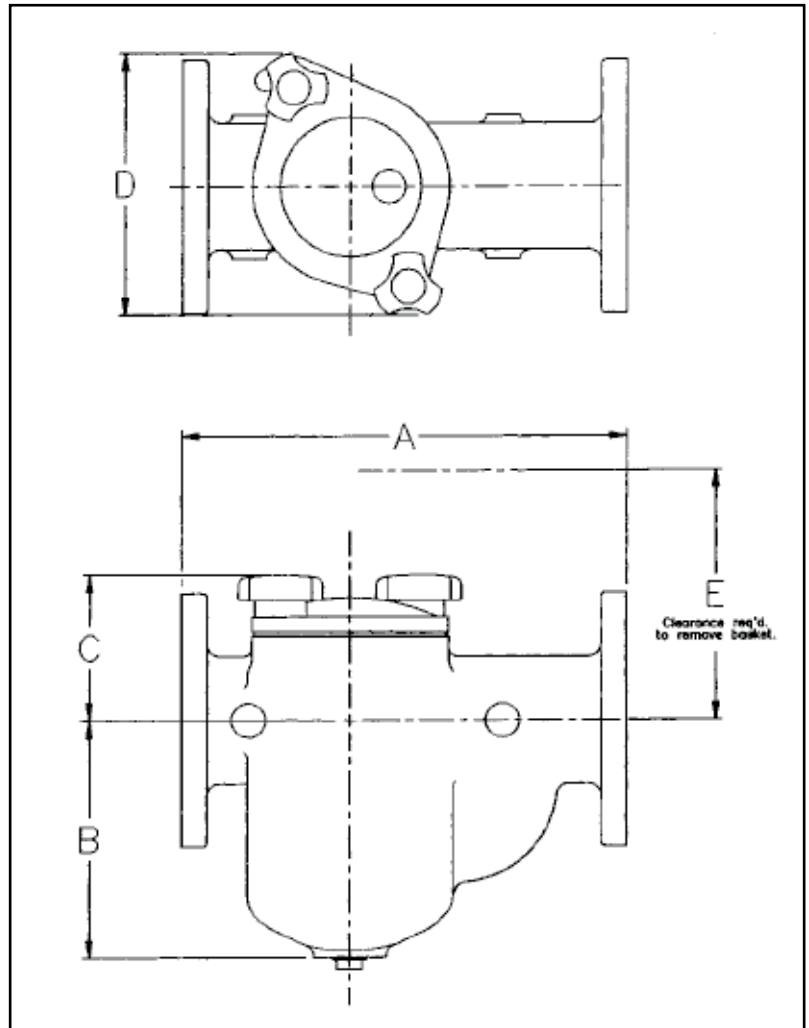

UNIT SIZE	THREADED			FLANGED					
	2"	2½"	3"	2"	2½"	3"	4"	6"	8"
A	8.75	10.25	11.63	10.50	11.63	13.13	16.75	19.63	27.00
B	7.38	5.88	7.00	7.38	5.88	7.00	10.13	14.50	18.38
C	3.81	4.06	4.57	3.81	4.06	4.57	5.32	7.13	8.81
D	4.63	6.75	6.97	6.00	7.00	7.50	9.00	11.00	13.50
E	9.50	7.88	10.13	9.50	7.88	10.13	14.63	19.63	28.75
Weight (lbs)	14	24	34	24	34	52	93	198	435

These dimensions are for reference only. For installation purposes, request certified drawings.