

Tate Andale Model 245A Threeway Disc Valve

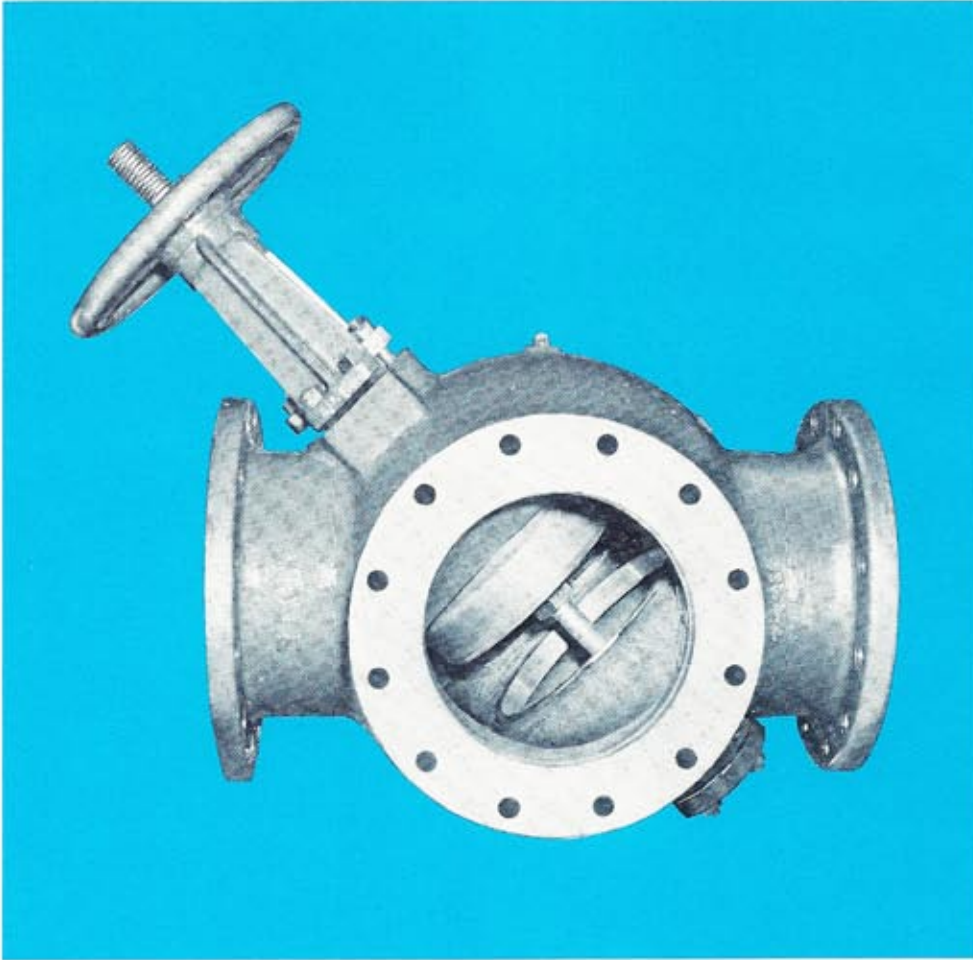

Description

Tate Andale Model 245A Threeway Disc Valves are used where a stream from a single line is to be directed to either of two parallel lines, or to both. Used where two single-flow valves, if closed simultaneously, would cause danger or destruction. To connect two safety valves, or safety discs, in parallel, on a single pressure vessel. To valve vapor from a single evaporator to two condensers in parallel.

Typical Valve Specification

The Valve shall be a Type 245A Threeway Valve as manufactured by Tate Andale, Inc. and suitable for a working pressure of 125/150 psig (cast iron/cast steel) at 200°F.

The valve body shall be cast iron or cast steel construction with _____ — 125/150 #ANSI flanged connections. The valve seats shall be steel, bronze or cast iron, the valve disc shall be bronze, cast iron or cast steel, and the valve spindle shall be bronze or steel.

Standard Materials

Body Cast Iron, Cast Steel
Trim..... Bronze, Steel

Standard Features

- External screw & yoke
- Pressed in valve seats
- Valve position is indicated by the position of the valve stem

Optional Features

- Higher design pressures
- Chain operation
- Automatic operation
 - Electric Motor
 - Pneumatic
- Stainless steel trim
- Hastalloy C trim
- Inconel/Monel trim
- Other body and trim materials for special applications

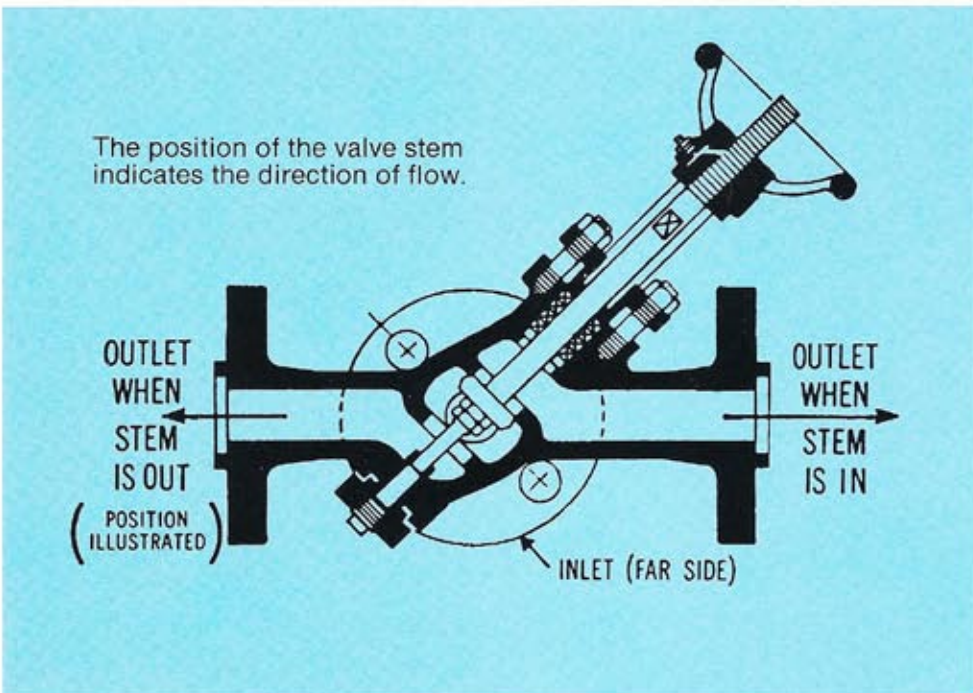

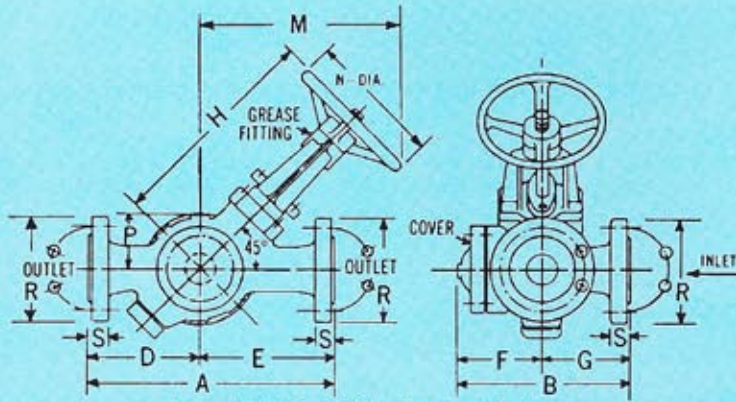

In the tabulation "SIZE" is the nominal diameter of the Valve's Inlet and Outlet openings

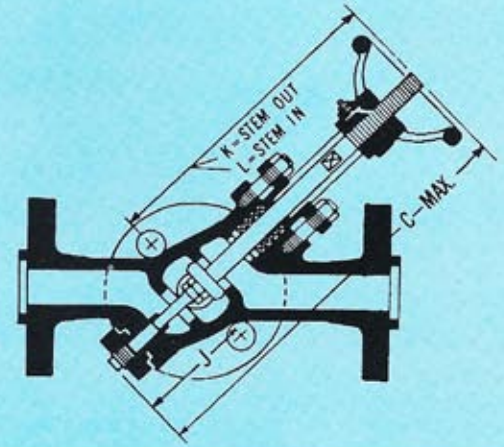

*Weight in pounds

VALVE TYPE	SIZE	A	B	C	D	E	F	G	H	J	K	L	M	N	P	R	S	WT.*
245A CAST IRON CAST STEEL	1"	7½	5	10¾	3¼	4¼	2½	2½	8½	2½	8½	7¼	7½	4	—	4¼	7/16	30
	1¼"	9¼	6	13½	4	5¼	3	3	10½	3½	10½	9	8¼	5	—	4¾	½	40
	1½"	9¼	6	13½	4	5¼	3	3	10½	3½	10½	9	8¼	5	—	5	9/16	45
125 PSIG Design	2"	11¼	7¼	15	5	6¼	3½	3¾	10¾	4½	10¼	9½	9	5	—	6	5/8	65
	2½"	13	10¼	17¼	6½	6½	5¼	5	11½	5	10¾	12¼	10¼	7	3½	7	1½/16	80
	3"	13	10¼	17¼	6½	6½	5¼	5	11½	5	10¾	12¼	10¼	7	3½	7½	¾	90
ANSI Class 125 Flanges	4"	16	11¾	23	8	8	6	5¼	15¼	7	14¼	16	13½	8	4¾	9	15/16	150
	6"	19½	16½	27¾	9¾	9¾	8½	8	18	8½	17¼	19¼	16	10	6½	11	1	300
	8"	24	21	34	12	12	12	9	21½	11	20¼	23	19½	12	8¼	13½	1½	450
	10"	28	25	38¾	14	14	14	11	24½	12½	23	26¼	21¼	12	10	16	1¾/16	675
	12"	33	28½	45	16½	16½	15½	13	26½	14¼	27	30¾	24	16	12¼	19	1¼	1000

2453A CAST STEEL	1"	9¾	5¾	11½	4½	5¼	2½	3¼	8¼	2½	7¼	8½	7½	4	—	4¾	1¼/16	40
	1¼"	11¾	6¾/16	14½	5¾/16	6¾/16	2½	3¼/16	10¾	3½	9¾/16	10¾/16	9½	6	—	5¼	¾	50
	1½"	11¾	6¾/16	14½	5¾/16	6¾/16	2½	3¼/16	10¾	3½	9¾/16	10¾/16	9½	6	—	6¾	13/16	60
300 PSIG Design	2"	15¼	10¾	20	7¾	7¾	5	5¾	13¾	6½	12½	13¾	12	7	3¾	6½	7/8	100
	2½"	17¼	11¾	21	8¾	8¾	5¼	6½	13½	6½	13	14½	12½	8	4¾	7½	1	130
ANSI Class 300 Flanges	3"	18¼	12¾	24¾	9¾	9¾	6	6¾	16¼	7½	15½	17	14¾	9	4¾/16	8¼	1½	225
	4"	22	14¼	27¼	11	11	6¾	7½	18½	7¾	17¾	19¾	17	12	5	10	1¼	350
	6"	27¾	20¾/16	35¾	12¾/16	14¾/16	11	9¾/16	24	11	22¼	24¾	22½	16	7	12½	17¾/16	650

2453A CAST STEEL	1"	10¼	6	11½	4¾	5½	2½	3½	8¼	2½	7¼	8½	7½	4	—	4¾	15/16	40
	1¼"	12	6¾	14½	5½	6½	2½	4	10¾	3½	9¾/16	10¾/16	9½	6	—	5¼	1¼/16	50
	1½"	12	6¾	14½	5½	6½	2½	4	10¾	3½	9¾/16	10¾/16	9½	6	—	6¾	1½	60
600 PSIG Design	2"	16	11	20	8	8	5	6	13¾	6½	12½	13¾	12	7	3¾	6½	1¼	100
	2½"	18	12¼	21	9	9	5¼	6½	13½	6½	13	14½	12½	8	4¾	7½	1¾	130
ANSI Class 600 Flanges	3"	19	13	24¾	9½	9½	6	7	16¼	7½	15½	17	14¾	9	4¾/16	8¼	1½	225
	4"	23	14¾	27¼	11½	11½	6¾	8	18½	7¾	17¾	19¾	17	12	5	10¾	1¾	350
	6"	28¾	21	35¾	13¼	15¼	11	10	24	11	22¼	24¾	22½	16	7	14	2½	650

2454A CAST STEEL	1"	12¾	7¼/16	16¾	5¼/16	6¼/16	3½	4¾/16	12¼	4½	10¾	11¾	10¾	6	—	4¾	15/16	65
	1¼"	14¾	8¼/16	18½	6¾/16	7¾/16	3¾	5¾/16	13¾	5¼	12¾	13¼	11¾	7	—	5¼	1¼/16	95
	1½"	14¾	9	18½	6¾	7¾	3¾	5¼	13¾	5¼	12¾	13¼	11¾	7	—	6¾	1½	100
600 PSIG Design	2"	17¾	14¼/16	22	8¾/16	9¾/16	7¾	6¼/16	14¼	7	13½	15	12½	8	4	6½	1¼	160
	2½"	20¾	15¼/16	27½	9¾/16	11¾/16	8½	7¾/16	19¾	7¼	18½	20¼	18	12	4¾	7½	1¾	380
ANSI Class 600 Flanges	3"	21¾	16¾/16	27½	9¼/16	11¼/16	8½	7¼/16	19¾	7¼	18½	20¼	18	12	4¾	8¼	1½	400
	4"	25¾	18¼/16	34	11¼/16	13¼/16	9½	9¾/16	23½	10	22	24	22	16	5¼	10¼	1¾	600
	6"	33¼	25¾	42¾	16¾	17¾	13¾	11¾	30	12¾	25½	27½	28	20	7¼	14	2½	1000

2454A CAST STEEL	1"	13½	8¼	16¾	6¼	7¼	3½	4¾	12¼	4½	10¾	11¾	10¾	6	—	5¾	1¾	65
	1¼"	14¾	9¾	18½	6¾	7¾	3¾	5¾	13¾	5¼	12¾	13¼	11¾	7	—	6¼	1¾	95
	1½"	15	9¼	18½	7	8	3¾	5½	13¾	5¼	12¾	13¼	11¾	7	—	7	1½	100
900 PSIG Design	2"	19	15¼	22	9	10	7¾	7½	14¼	7	13½	15	12½	8	4	8½	1¾/16	160
	2½"	22	16½	27½	10	12	8½	8	19¾	7¼	18½	20¼	18	12	4¾	9¾	1¾/16	380
ANSI Class 900 Flanges	3"	22	16½	27½	10	12	8½	8	19¾	7¼	18½	20¼	18	12	4¾	9¾	1¾/16	400
	4"	26	19	34	12	14	9½	9½	23½	10	22	24	22	16	5¼	11½	2¼/16	600
	6"	34	25¾	42¾	16½	17½	13¾	12	30	12¾	25½	27½	28	20	7¼	15	2½	1000